

DATOS TECNICOS	
ALIMENTACION	230 V.
FRECUENCIA	50 Hz.
TENSION MOTOR	24 V. C.C.
POTENCIA MOTOR	60 W
ABSORCION	2.5 A
RPM MOTORREDUCTOR	60 RPM
PAR NOMINAL	4 Nm
PAR DE ARRANQUE	7 Nm
FACTOR DE SERVICIO	INTENSIVO
TEMP. FUNCIONAMIENTO	-40 +80
TRANSMISION	CADENA 1/2" ANCHO 4.5
FUERZA DE ARRASTRE	241 N
VELOCIDAD PUERTA	6.25 m/min.
PESO MAX. PUERTA	123 Kg.
M2 MAX. PUERTA	10 m2
NIVEL SONORO	XXdB
GRADO DE PROTECCION	IP 51

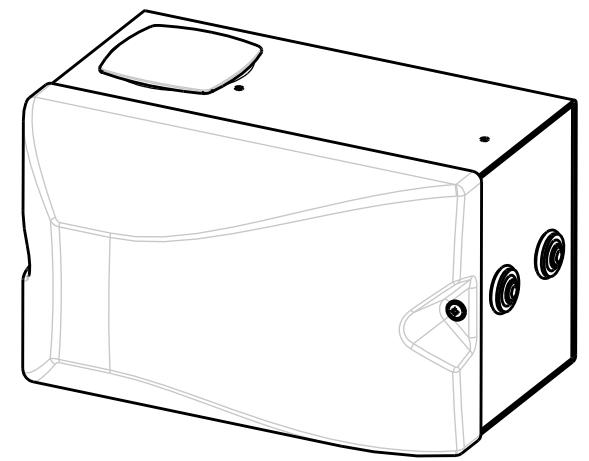

ESCALA 0.400

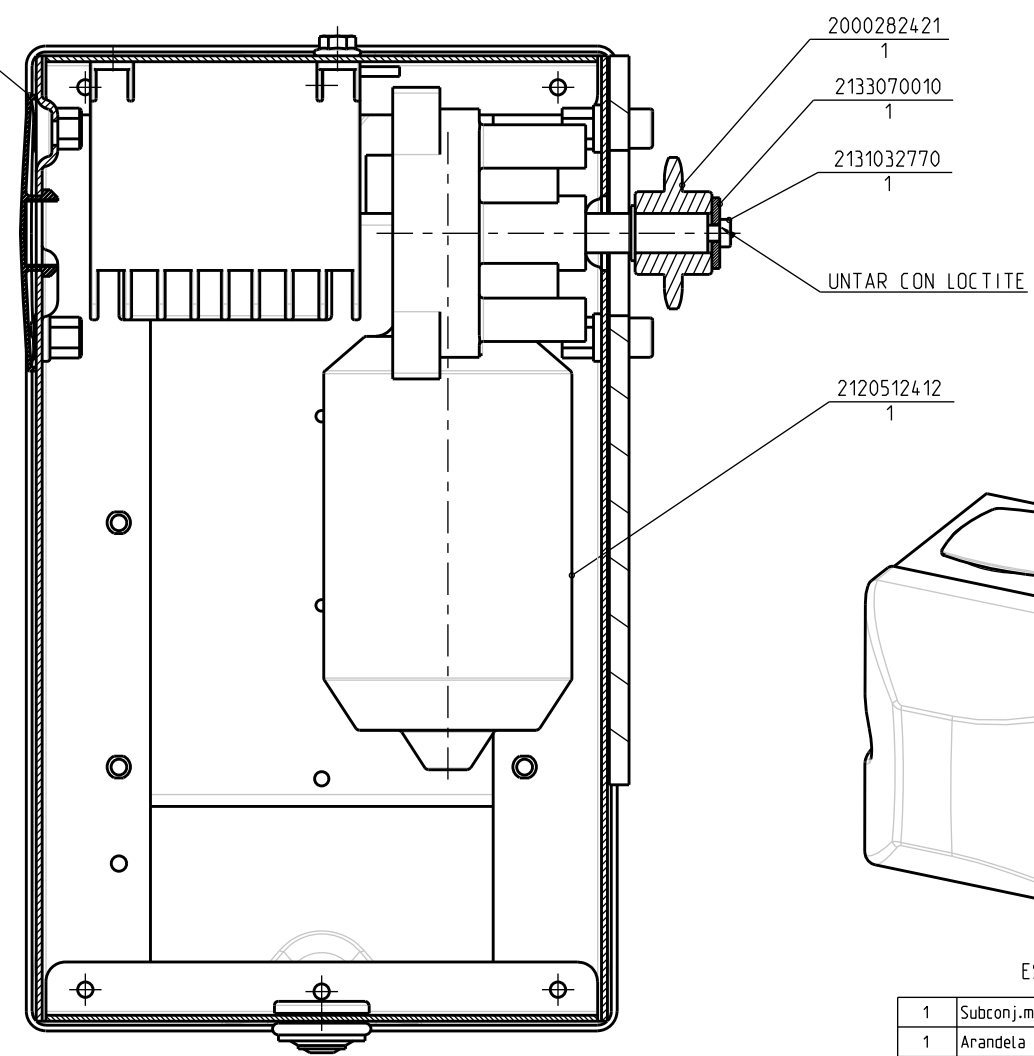
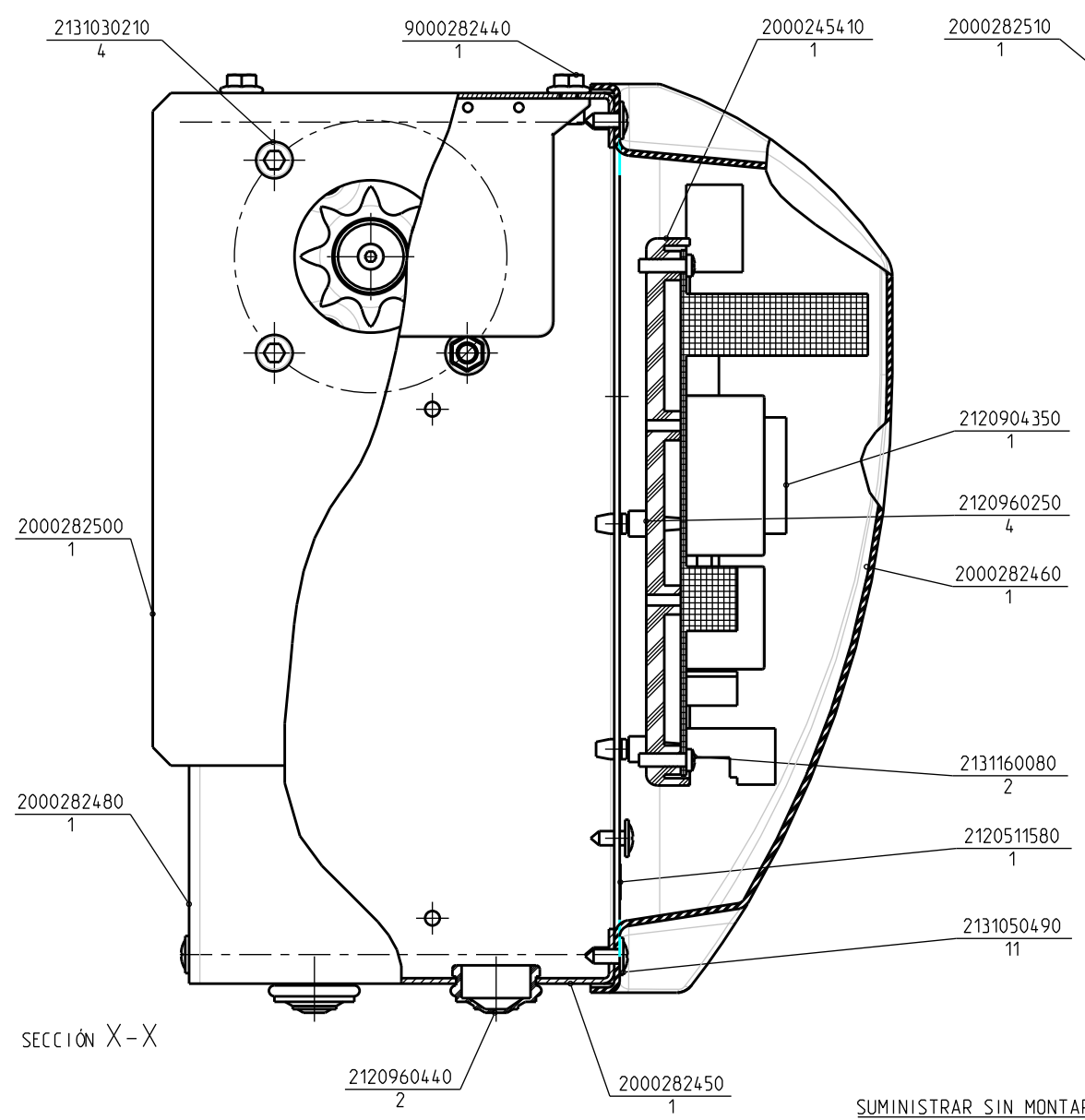
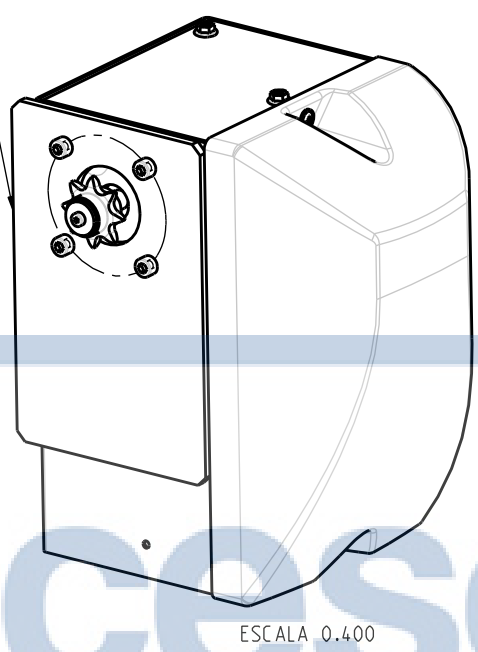
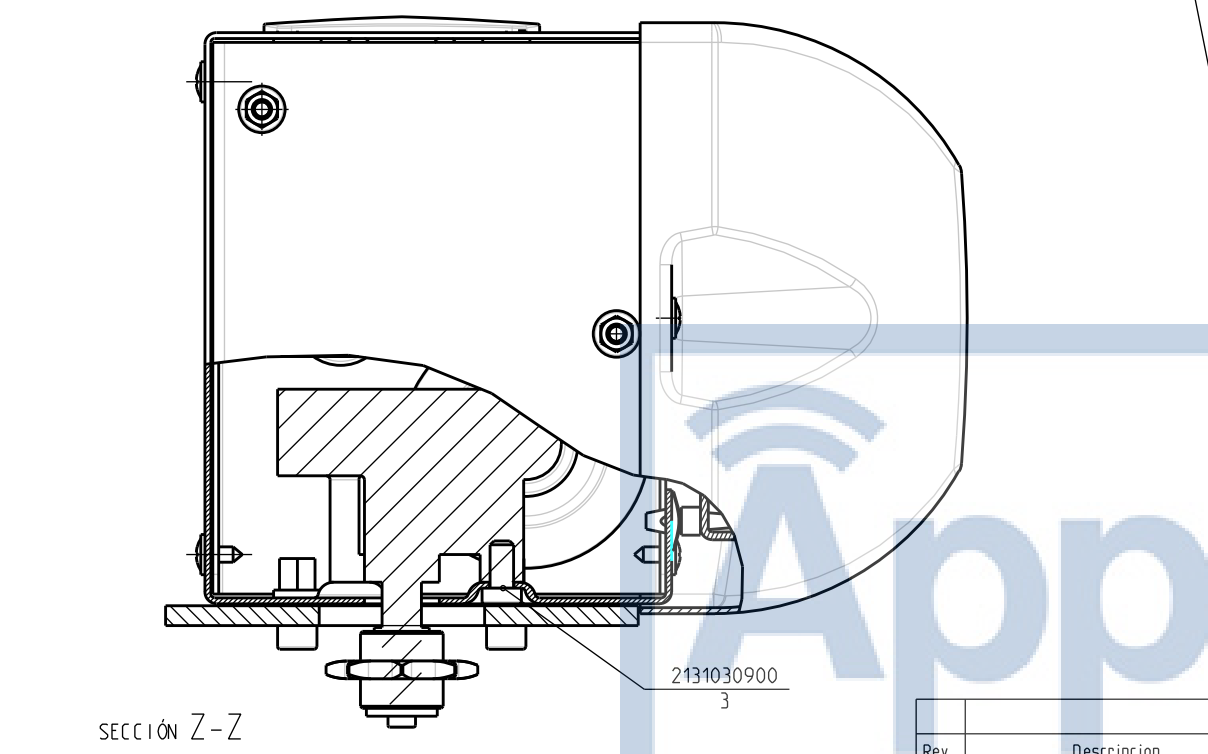

QTY	DESCRIPTION	REF.	QTY	REF.
1	Subconj.montura trafor UPPER	9000282440	0	-
1	Arandela	2133070010	0	PA-6 SKYFFY
2	Torn.atomado mortaja cruzada	2131160080		3.6X13 CL81Z
11	Torn.cabeza alomada ancha	2131050490		3.9x9.5 ch88h
1	Tornillo cilindrico	2131032770		M4x10 DIN7984-8.8 cinc.
3	Tornillo cilindrico	2131030900		M6x12 DIN7984-8.8 cinc.
4	Tornillo cilindrico	2131030210	---	M6x16 DIN912-8.8 cinc.
2	Entrada conica negra	2120960440	0	AERF
4	Soporte P.C.I	2120960250		LBCS-2-3 RICHCO
1	Instalacion electr.24V	2120904350		
1	Motorreductor24V.cc.d63 lzq.	2120512412	0	elvi 102.607FCE
1	Simbolo tierras ref.1700480002	2120511580	0	WEIDM
1	Hole cover	2000282510	1	ABS (BLACK)
1	Herraje fijacion UPPER	2000282500	0	ST.37.2
1	Chasis UPPER	2000282480	0	Chapa Ac.1.5mm.
1	Proteccion centralita	2000282460	0	POLIESTIRENO NEGRO
1	Tapa pasacables	2000282450	0	Chapa Ac. 1.5 mm.
1	Pinon 8 dientes UPPER	2000282421	1	F-1140
1	Base instalacion electrica	2000245410		Polipropileno negro

TOL. LINEALES Y CILINDRICAS	TOL. ANGULAR (longitud corto)	TOL. ANGULAR (longitud largo)	TOL. SUPERFICIES (R) CHAPLANES
de 0.5 a 30 ±0.1	Hasta 10 ±0.1	mas de 10 a 50 ±0.1	mas de 0.5 a 3 ±0.2
mas de 30 a 120 ±0.2	mas de 10 a 50 ±0.2	mas de 50 a 120 ±0.2	mas de 3 a 6 ±0.5
mas de 120 a 400 ±0.3	mas de 50 a 120 ±0.3	mas de 120 a 300 ±0.5	mas de 6 a 30 ±1
mas de 400 a 1000 ±0.5	mas de 120 a 300 ±0.5	mas de 300 a 1000 ±1	mas de 30 a 100 ±1
mas de 1000 a 2000 ±1	mas de 1000 a 2000 ±1	mas de 2000 a 5000 ±1.5	mas de 100 a 500 ±1.5
mas de 2000 ±1.5	mas de 2000 a 5000 ±1.5	mas de 5000 a 10000 ±2	mas de 500 a 1000 ±2

ACCIONADOR DE PUERTAS BASCULANTES TIPO UPPER		
1 Accionador UPPER sin mano	-	-
Escala	1/1.25	-
Designacion	Peso (Kg)	Tratamiento
Dibujado: 14-9-2006 E.López	Sustituye a:	Revision
Comprobado: 2-3-2007	Sustituido por:	0

PUJOL MUNTALA	P2TCDC000
----------------------	-----------

Rev.	Descripcion	Observaciones	Fecha	Nombre

Salvo indicacion expresa, las aristas resultantes de las mecanizaciones no se dejan ranas
Este plano es propiedad de PUJOL MUNTALA, S.A. y queda prohibido reproducirlo sin autorizacion